



# Rotary Vane Pumps

## PICOLINO

### MODELS

VTE 3  
DTE 3  
VTE 6  
DTE 6  
VTE 8  
DTE 8  
VTE 10  
DTE 10

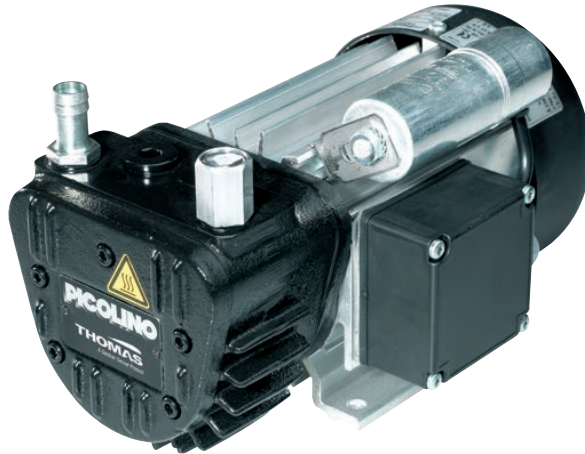

**OIL-LESS**

### FEATURES

- Oil-less
- Long life
- Compact
- Low noise
- Pulsation free
- Low vibration

### TYPICAL APPLICATIONS

- Vacuum lifting
- Vacuum holding
- Automation/Pick and place
- Medical
- Printing
- Gas analysis/sampling
- Aeration











**THOMAS**  
by Gardner Denver

# Rotary Vane Pump



## Product Overview

Model	Flow	Max. vacuum	Max. pressure	Page
 <b>VTE 3</b>	3,5/4,2 m <sup>3</sup> /hr	85%	-	3
 <b>DTE 3</b>	3,5/4,2 m <sup>3</sup> /hr	-	1,0 bar	4
 <b>VTE 6</b>	6,0/7,2 m <sup>3</sup> /hr	85%	-	5
 <b>DTE 6</b>	6,0/7,2 m <sup>3</sup> /hr	-	1,0 bar	6
 <b>VTE 8</b>	8,0/9,6 m <sup>3</sup> /hr	85%	-	7
 <b>DTE 8</b>	8,0/9,6 m <sup>3</sup> /hr	-	1,0 bar	8
 <b>VTE 10</b>	10,0/12,0 m <sup>3</sup> /hr	85%	-	9
 <b>DTE 10</b>	10,0/12,0 m <sup>3</sup> /hr	-	1,0 bar	10



# Rotary Vane Pump VTE 3

# PICOLINO

<b>Flow</b>	<b>3,5/4,2 m<sup>3</sup>/h</b>
<b>Max. vacuum</b>	<b>85%</b>

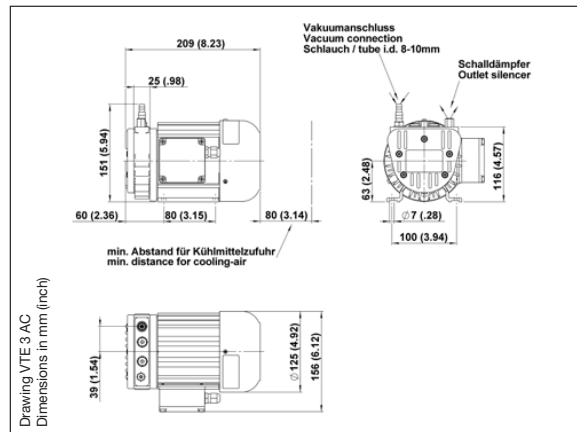

Pneumatic Data				
Description	VTE 3 230/50/60	VTE 3 115/50/60	VTE 3 Three-phase 50/60	VTE 3 24 DC
Part number	<b>25130110</b>	<b>25130111</b>	<b>25130113</b>	<b>25130172</b>
Max. flow	3,5/4,2 m <sup>3</sup> /h	3,5/4,2 m <sup>3</sup> /h	3,5/4,2 m <sup>3</sup> /h	3,5 m <sup>3</sup> /h
Max. intermittent vacuum	85%	85%	85%	85%
Max. continuous vacuum	85%	85%	85%	85%

Electrical Data				
Motor type	Capacitor	Capacitor	Three-phase	Permanent magnet
Nominal voltage	230 V ±10 % 50/60 Hz	100 V ±10 % 50 Hz 100-115 V ±10 % 60 Hz	200-255/346-440 V 50 Hz 200-277/346-480 V 60 Hz	24 V DC 24 V DC
Nominal speed	2750/3250 rpm	2750/3300 rpm	2860/3360 rpm	2850 rpm
Motor rating	0,120/0,145 kW	0,120/0,145 kW	0,120/0,145 kW	0,120 kW
Current consumption	1,3/1,4 A	2,7/2,9 A	1,12/0,71/1,02/0,62 A	10,5 A
Motor insulation class	F	F	F	F
Protection class	IP54	IP54	IP54	IP55
Thermal protector	yes	yes	no	no
UL recognized motor	no	yes	no	no

General Data				
Ambient temperature	0 to 50 °C	0 to 50 °C	0 to 50 °C	0 to 50 °C
Weight	6,5 kg	6,5 kg	6,5 kg	7,9 kg
Direction of rotation	ccw	ccw	ccw	ccw
Average noise level	55/57 dB (A)	55/57 dB (A)	55/57 dB (A)	62 dB (A)

All listed flow values relate to air at the pump inlet condition (i.e. expanded under vacuum).  
Further information (general usage, installation, servicing etc.) is available in the operating instructions manual.  
Further UL recognized motor on request.

## Flow Curves

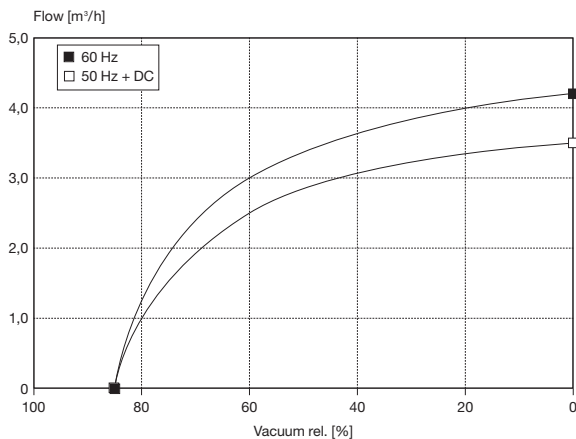

### Supplied as standard:

Tube connector G 1/8  
(Tube I.D. 8 – 10 mm)  
Outlet silencer G 1/8

### Accessories:

Vacuum regulator ZRV 6 G 1/8  
(part number 31430)  
Non-return valve ZRK 6 G 1/8  
(part number 61802)

### Service Parts:

Service kit (part number 25130104)

consists of:

- 4 x Vanes
- 1 x Filter cartridge
- 2 x Filter seal (ring)
- 1 x Filter seal
- 3 x Gasket (copper)
- 1 x O-ring (inside silencer)

2513...

Stock programme

The information presented in this material is based on technical data and test results of nominal units. It is believed to be accurate and reliable and is offered as an aid to help in the selection of Thomas products. It is the responsibility of the user to determine the suitability of the product for the intended use and the user assumes all risk and liability whatsoever in connection therewith. Thomas does not warrant, guarantee or assume any obligation or liability in connection with this information.

**THOMAS**  
by Gardner Denver

# Rotary Vane Pump DTE 3



<b>Flow</b>	<b>3,5/4,2 m<sup>3</sup>/h</b>
<b>Max. pressure</b>	<b>1,0 bar</b>

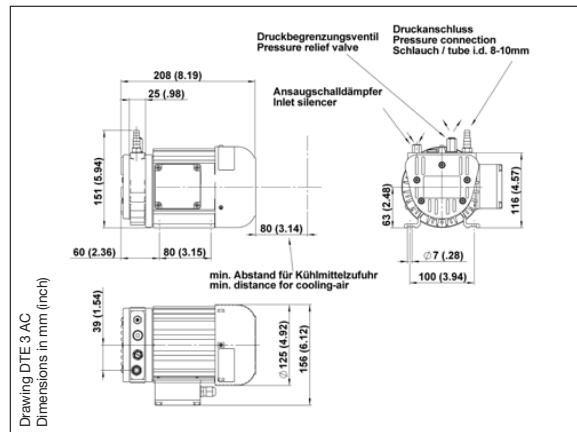

Pneumatic Data				
Description	DTE 3 230/50/60	DTE 3 115/50/60	DTE 3 Three-phase 50/60	DTE 3 24 DC
Part number	25140210	25140211	25140213	25140272
Max. flow	3,5/4,2 m <sup>3</sup> /h	3,5/4,2 m <sup>3</sup> /h	3,5/4,2 m <sup>3</sup> /h	3,5 m <sup>3</sup> /h
Max. intermittent pressure	1,0 bar	0,8 bar	1,0 bar	1,0 bar
Max. continuous pressure	1,0 bar	0,8 bar	1,0 bar	1,0 bar

Electrical Data				
Motor type	Capacitor	Capacitor	Three-phase	Permanent magnet
Nominal voltage	230 V ±10 % 50/60 Hz	100 V ±10 % 50 Hz 100-115 V ±10 % 60 Hz	200-255/346-440 V 50 Hz 200-277/346-480 V 60 Hz	24 V DC
Nominal speed	2750/3250 rpm	2750/3300 rpm	2860/3360 rpm	2850 rpm
Motor rating	0,120/0,145 kW	0,120/0,145 kW	0,120/0,145 kW	0,120 kW
Current consumption	1,3/1,4 A	2,7/2,9 A	1,12/0,71/1,02/0,62 A	10,5 A
Motor insulation class	F	F	F	F
Protection class	IP54	IP54	IP54	IP55
Thermal protector	yes	yes	no	no
UL recognized motor	no	yes	no	no

General Data				
Ambient temperature	0 to 50 °C	0 to 50 °C	0 to 50 °C	0 to 50 °C
Weight	6,5 kg	6,5 kg	6,5 kg	7,9 kg
Direction of rotation	ccw	ccw	ccw	ccw
Average noise level	57/58 dB (A)	57/58 dB (A)	57/58 dB (A)	64 dB (A)

All listed flow values relate to air at standard atmospheric conditions.  
Further information (general usage, installation, servicing etc.) is available in the operating instructions manual.  
Further UL recognized motor on request.

## Flow Curves

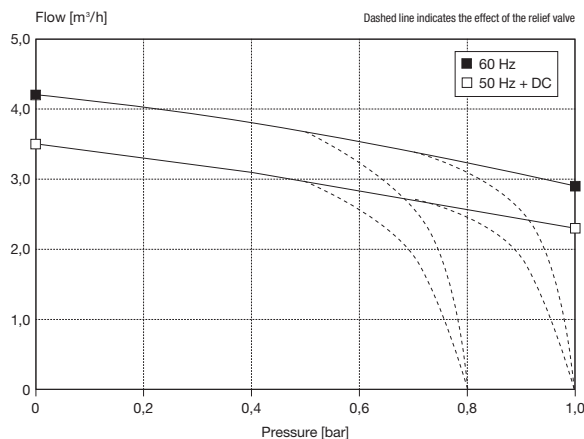

### Supplied as standard:

- Tube connector G 1/8 (Tube I.D. 8 – 12 mm)
- Inlet silencer G1/8
- Pressure relief valve (0,8/1,0 bar) G 1/8

### Service Parts:

- Service kit (part number 25130104) consists of:
  - 4 x Vanes
  - 1 x Filter cartridge
  - 2 x Filter seal (ring)
  - 1 x Filter seal
  - 3 x Gasket (copper)
  - 1 x O-ring (only for VTE needed)

The information presented in this material is based on technical data and test results of nominal units. It is believed to be accurate and reliable and is offered as an aid to help in the selection of Thomas products. It is the responsibility of the user to determine the suitability of the product for the intended use and the user assumes all risk and liability whatsoever in connection therewith. Thomas does not warrant, guarantee or assume any obligation or liability in connection with this information.

### Accessories:

- Pressure regulator ZRD 6 G 1/8 (part number 31429)
- Non-return valve ZRK 6 G 1/8 (part number 61802)

2514... Stock programme



# Rotary Vane Pump VTE 6

# PICOLINO

<b>Flow</b>	<b>6,0/7,2 m<sup>3</sup>/h</b>
<b>Max. vacuum</b>	<b>85%</b>

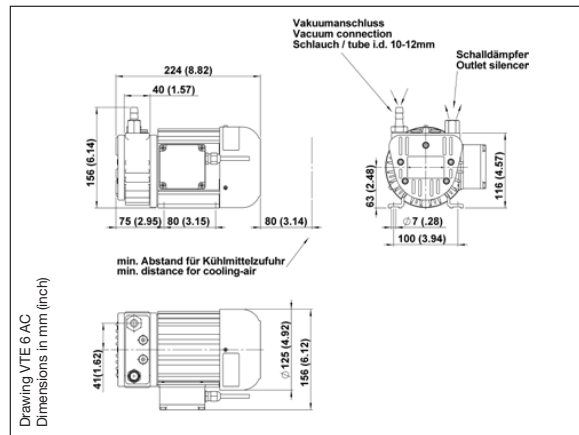

Pneumatic Data				
Description	VTE 6 230/50/60	VTE 6 115/50/60	VTE 6 Three-phase 50/60	VTE 6 24 DC
Part number	<b>25160112</b>	<b>25160120</b>	<b>25160114</b>	25160170
Max. flow	6,0/7,2 m <sup>3</sup> /h	6,0/7,2 m <sup>3</sup> /h	6,0/7,2 m <sup>3</sup> /h	6,0 m <sup>3</sup> /h
Max. intermittent vacuum	85%	85%	85%	85%
Max. continuous vacuum	85%	85%	85%	85%

Electrical Data				
Motor type	Capacitor	Capacitor	Three-phase	Permanent magnet
Nominal voltage	230 V ±10 % 50/60 Hz	100 V ±10 % 50 Hz 100-115 V ±10 % 60 Hz	200-255/346-440 V 50 Hz 200-277/346-480 V 60 Hz	24 V DC
Nominal speed	2700/3150 rpm	2700/3250 rpm	2800/3320 rpm	3250 rpm
Motor rating	0,25/0,30 kW	0,25/0,30 kW	0,25/0,30 kW	0,25 kW
Current consumption	2,3/2,5 A	5,0/5,2 A	1,4/0,81/1,6/0,9 A	18,0 A
Motor insulation class	F	B	B	F
Protection class	IP54	IP54	IP54	IP55
Thermal protector	yes	yes	no	yes
UL recognized motor	no	yes	no	no

General Data				
Ambient temperature	0 to 50 °C	0 to 50 °C	0 to 50 °C	0 to 50 °C
Weight	7,5 kg	7,5 kg	7,5 kg	8,5 kg
Direction of rotation	ccw	ccw	ccw	ccw
Average noise level	57/59 dB (A)	57/59 dB (A)	57/59 dB (A)	64 dB (A)

All listed flow values relate to air at the pump inlet condition (i.e. expanded under vacuum).  
Further information (general usage, installation, servicing etc.) is available in the operating instructions manual.  
Further UL recognized motor on request.

## Flow Curves

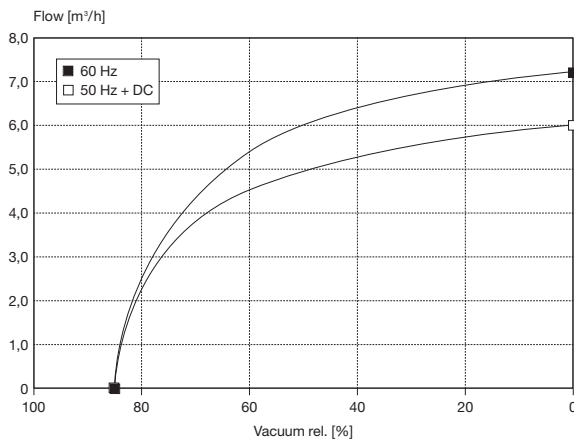

### Supplied as standard:

Tube connector G 3/8  
(Tube I.D. 10 – 12 mm)  
Outlet silencer G 3/8

### Accessories:

Vacuum regulator ZRV 6 G 1/8  
(part number 31430)  
Non-return valve ZRK 12 G 3/8  
(part number 61803)

### Service Parts:

Service kit (part number 25160104)  
consists of:  
4 x Vanes  
1 x Filter cartridge  
2 x Filter seal (ring)  
1 x Filter seal  
3 x Gasket (copper)  
1 x O-ring (inside silencer)

The information presented in this material is based on technical data and test results of nominal units. It is believed to be accurate and reliable and is offered as an aid to help in the selection of Thomas products. It is the responsibility of the user to determine the suitability of the product for the intended use and the user assumes all risk and liability whatsoever in connection therewith. Thomas does not warrant, guarantee or assume any obligation or liability in connection with this information.

**2516...** Stock programme

**THOMAS**  
by Gardner Denver

# Rotary Vane Pump DTE 6



<b>Flow</b>	<b>6,0/7,2 m<sup>3</sup>/h</b>
<b>Max. pressure</b>	<b>1,0 bar</b>

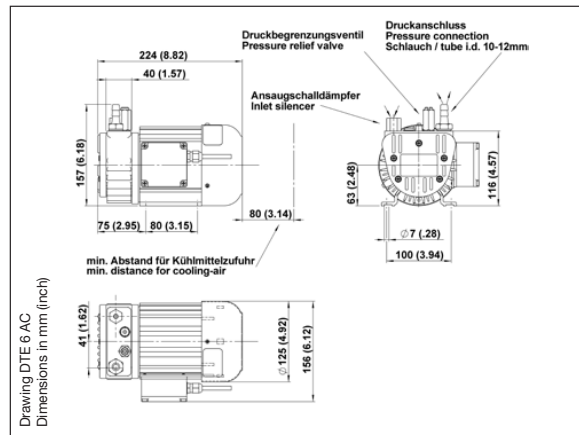

Pneumatic Data				
Description	DTE 6 230/50/60	DTE 6 115/50/60	DTE 6 Three-phase 50/60	DTE 6 24 DC
Part number	25170212	25170220	25170214	25170270
Max. flow	6,0/7,2 m <sup>3</sup> /h	6,0/7,2 m <sup>3</sup> /h	6,0/7,2 m <sup>3</sup> /h	6,0 m <sup>3</sup> /h
Max. intermittent pressure	1,0 bar	1,0 bar	1,0 bar	1,0 bar
Max. continuous pressure	1,0 bar	1,0 bar	1,0 bar	1,0 bar

Electrical Data				
Motor type	Capacitor	Capacitor	Three-phase	Permanent magnet
Nominal voltage	230 V ±10 % 50/60 Hz	100 V ±10 % 50 Hz 100-115 V ±10 % 60 Hz	200-255/346-440 V 50 Hz 200-277/346-480 V 60 Hz	24 V DC
Nominal speed	2700/3150 rpm	2700/3250 rpm	2800/3320 rpm	3250 rpm
Motor rating	0,25/0,30 kW	0,25/0,30 kW	0,25/0,30 kW	0,25 kW
Current consumption	2,3/2,5 A	5,0/5,2 A	1,4/0,81/1,6/0,9 A	18,0 A
Motor insulation class	F	B	B	F
Protection class	IP54	IP54	IP54	IP55
Thermal protector	yes	yes	no	yes
UL recognized motor	no	yes	no	no

General Data				
Ambient temperature	0 to 50 °C	0 to 50 °C	0 to 50 °C	0 to 50 °C
Weight	7,5 kg	7,5 kg	7,5 kg	8,5 kg
Direction of rotation	ccw	ccw	ccw	ccw
Average noise level	60/61 dB (A)	60/61 dB (A)	60/61 dB (A)	66 dB (A)

All listed flow values relate to air at standard atmospheric conditions.  
Further information (general usage, installation, servicing etc.) is available in the operating instructions manual.  
Further UL recognized motor on request.

## Flow Curves

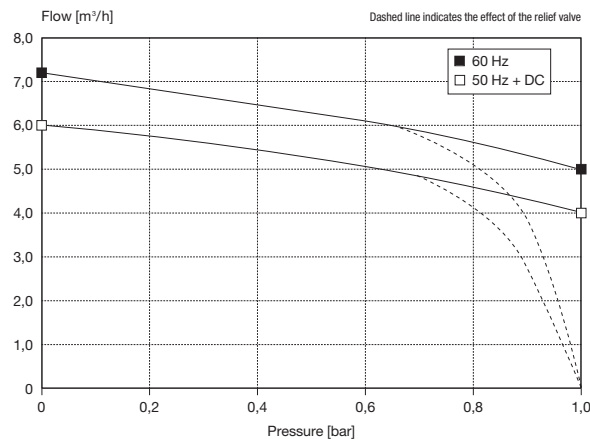

## Supplied as standard:

- Tube connector G 3/8 (Tube I.D. 10 – 12 mm)
- Inlet silencer G 3/8
- Pressure relief valve (1,0 bar) G 1/8

## Service Parts:

- Service kit (part number 25160104) consists of:
  - 4 x Vanes
  - 1 x Filter cartridge
  - 2 x Filter seal (ring)
  - 1 x Filter seal
  - 3 x Gasket (copper)
  - 1 x O-ring (only for VTE needed)

The information presented in this material is based on technical data and test results of nominal units. It is believed to be accurate and reliable and is offered as an aid to help in the selection of Thomas products. It is the responsibility of the user to determine the suitability of the product for the intended use and the user assumes all risk and liability whatsoever in connection therewith. Thomas does not warrant, guarantee or assume any obligation or liability in connection with this information.

## Accessories:

- Pressure regulator ZRD 6 G 1/8 (part number 31429)
- Non-return valve ZRK 12 G 3/8 (part number 61803)

2517... Stock programme



# Rotary Vane Pump VTE 8

# PICOLINO

<b>Flow</b>	<b>8,0/9,6 m<sup>3</sup>/h</b>
<b>Max. vacuum</b>	<b>85%</b>

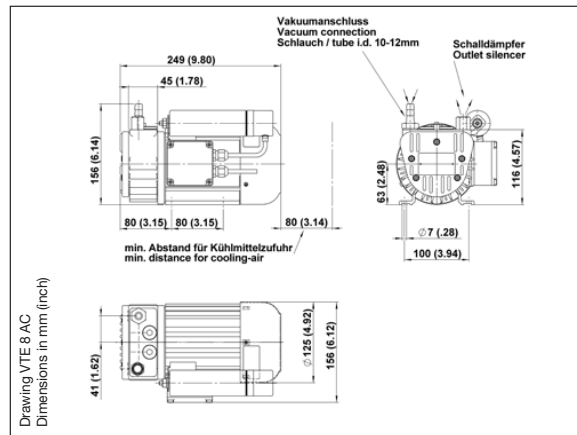

Pneumatic Data				
Description	VTE 8 230/50/60	VTE 8 115/50/60	VTE 8 Three-phase 50/60	VTE 8 24 DC
Part number	23630125	23630126	23630127	23630173
Max. flow	8,0/9,6 m <sup>3</sup> /h	8,0/9,6 m <sup>3</sup> /h	8,0/9,6 m <sup>3</sup> /h	8,0 m <sup>3</sup> /h
Max. intermittent vacuum	85%	85%	85%	85%
Max. continuous vacuum	85%	85%	85%	85%

Electrical Data				
Motor type	Capacitor	Capacitor	Three-phase	Permanent magnet
Nominal voltage	230 V ±10 % 50/60 Hz	100 V ±10 % 50 Hz 100-115 V ±10 % 60 Hz	200-255/346-440 V 50 Hz 200-277/346-480 V 60 Hz	24 V DC
Nominal speed	2700/3200 rpm	2750/3300 rpm	2850/3380 rpm	3300 rpm
Motor rating	0,35/0,42 kW	0,35/0,42 kW	0,37/0,44 kW	0,37 kW
Current consumption	3,9/3,4 A	9,0/8,4 A	2,77/1,60/2,25/1,30 A	21 A
Motor insulation class	F	F	F	F
Protection class	IP54	IP54	IP54	IP55
Thermal protector	yes	yes	no	no
UL recognized motor	no	yes	no	no

General Data				
Ambient temperature	0 to 50 °C	0 to 50 °C	0 to 50 °C	0 to 50 °C
Weight	8,0 kg	8,0 kg	8,0 kg	9,2 kg
Direction of rotation	ccw	ccw	ccw	ccw
Average noise level	59/61 dB (A)	59/61 dB (A)	59/61 dB (A)	66 dB (A)

All listed flow values relate to air at the pump inlet condition (i.e. expanded under vacuum).  
Further information (general usage, installation, servicing etc.) is available in the operating instructions manual.  
Further UL recognized motor on request.

## Flow Curves

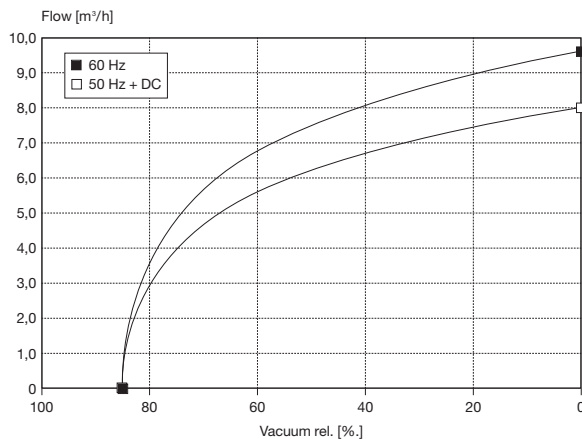

### Supplied as standard:

- Tube connector G 3/8 (Tube I.D. 10 – 12 mm)
- Outlet silencer G 3/8

### Service Parts:

- Service kit (part number 23630104) consists of:
  - 4 x Vanes
  - 1 x Filter cartridge
  - 2 x Filter seal (ring)
  - 1 x Filter seal
  - 3 x Gasket (copper)
  - 1 x O-ring (inside silencer)

The information presented in this material is based on technical data and test results of nominal units. It is believed to be accurate and reliable and is offered as an aid to help in the selection of Thomas products. It is the responsibility of the user to determine the suitability of the product for the intended use and the user assumes all risk and liability whatsoever in connection therewith. Thomas does not warrant, guarantee or assume any obligation or liability in connection with this information.

### Accessories:

- Vacuum regulator ZRV 12 G 3/8 (part number 31490)
- Non-return valve ZRK 12 G 3/8 (part number 61803)

2363... Stock programme

**THOMAS**  
by Gardner Denver

# Rotary Vane Pump DTE 8

# PICOLINO

<b>Flow</b>	<b>8,0/9,6 m<sup>3</sup>/h</b>
<b>Max. pressure</b>	<b>1,0 bar</b>

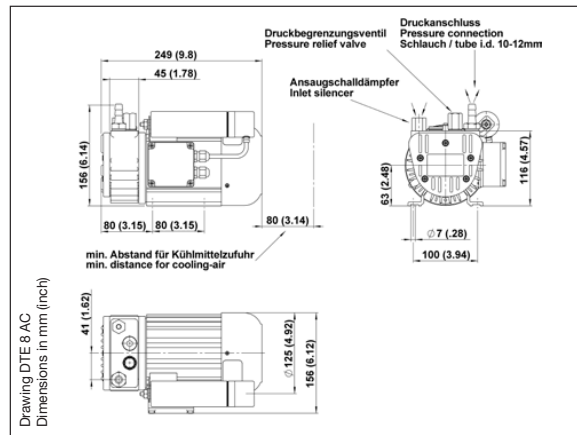
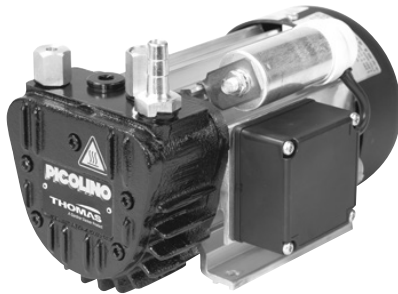

Pneumatic Data				
Description	DTE 8 230/50/60	DTE 8 115/50/60	DTE 8 Three-phase 50/60	DTE 8 24 DC
Part number	23660225	23660226	23660227	23660273
Max. flow	8,0/9,6 m <sup>3</sup> /h	8,0/9,6 m <sup>3</sup> /h	8,0/9,6 m <sup>3</sup> /h	8,0 m <sup>3</sup> /h
Max. intermittent pressure	0,8 bar	0,8 bar	1,0 bar	1,0 bar
Max. continuous pressure	0,8 bar	0,8 bar	1,0 bar	1,0 bar

Electrical Data				
Motor type	Capacitor	Capacitor	Three-phase	Permanent magnet
Nominal voltage	230 V ±10 % 50/60 Hz	100 V ±10 % 50 Hz 100-115 V ±10 % 60 Hz	200-255/346-440 V 50 Hz 200-277/346-480 V 60 Hz	24 V DC
Nominal speed	2700/3200 Upm	2750/3300 Upm	2850/3380 Upm	3300 Upm
Motor rating	0,35/0,42 kW	0,35/0,42 kW	0,37/0,44 kW	0,37 kW
Current consumption	3,9/3,4 A	9,0/8,4 A	2,77/1,60/2,25/1,30 A	21 A
Motor insulation class	F	F	F	F
Protection class	IP54	IP54	IP54	IP55
Thermal protector	yes	yes	no	no
UL recognized motor	no	yes	no	no

General Data				
Ambient temperature	0 to 50 °C	0 to 50 °C	0 to 50 °C	0 to 50 °C
Weight	8,0 kg	8,0 kg	8,0 kg	9,2 kg
Direction of rotation	ccw	ccw	ccw	ccw
Average noise level	62/63 dB (A)	62/63 dB (A)	62/63 dB (A)	67 dB (A)

All listed flow values relate to air at standard atmospheric conditions.  
Further information (general usage, installation, servicing etc.) is available in the operating instructions manual.  
Further UL recognized motor on request.

## Flow Curves

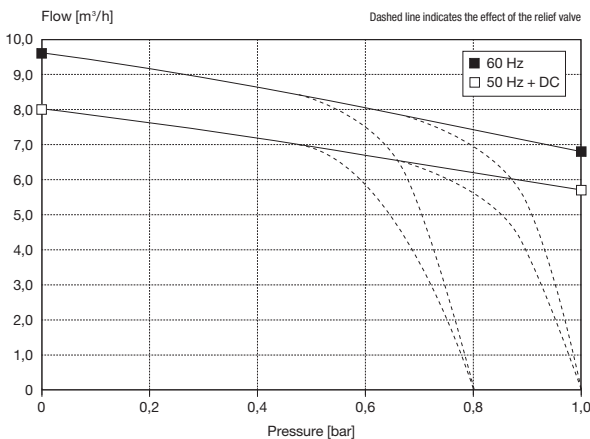

## Supplied as standard:

- Tube connector G 3/8 (Tube I.D. 10 – 12 mm)
- Inlet silencer G 3/8
- Pressure relief valve (0,6/1,0 bar) G 3/8

## Accessories:

- Pressure regulator ZRD 12 G 3/8 (part number 31431)
- Non-return valve ZRK 12 G 3/8 (part number 61803)

2366... Stock programme

## Service Parts:

- Service kit (part number 23630104) consists of:
- 4 x Vanes
- 1 x Filter cartridge
- 2 x Filter seal (ring)
- 1 x Filter seal
- 3 x Gasket (copper)
- 1 x O-ring (only for VTE needed)

The information presented in this material is based on technical data and test results of nominal units. It is believed to be accurate and reliable and is offered as an aid to help in the selection of Thomas products. It is the responsibility of the user to determine the suitability of the product for the intended use and the user assumes all risk and liability whatsoever in connection therewith. Thomas does not warrant, guarantee or assume any obligation or liability in connection with this information.

**THOMAS**  
by Gardner Denver



# Rotary Vane Pump VTE 10

# PICOLINO

<b>Flow</b>	<b>10/12 m<sup>3</sup>/h</b>
<b>Max. vacuum</b>	<b>85%</b>

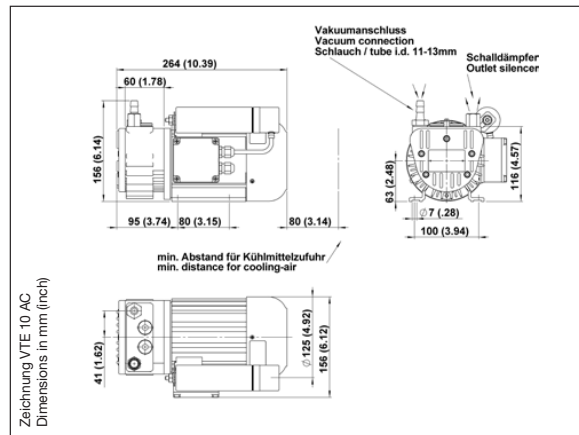
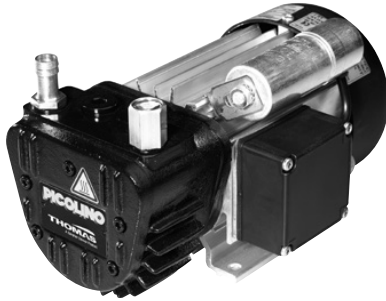

Pneumatic Data				
Description	VTE 10 230/50/60	VTE 10 115/50/60	VTE 10 Three-phase 50/60	VTE 10 24 DC
Part number	27740125	27740126	27740127	27740174
Max. flow	10/12 m <sup>3</sup> /h	10/12 m <sup>3</sup> /h	10/12 m <sup>3</sup> /h	10 m <sup>3</sup> /h
Max. intermittent vacuum	85%	85%	85%	85%
Max. continuous vacuum	85%	85%	85%	85%

Electrical Data				
Motor type	Capacitor	Capacitor	Three-phase	Permanent magnet
Nominal voltage	230 V ±10% 50/60Hz	100 V ±10% 50 Hz 100-115 V ±10% 60 Hz	200-255/346-440 V 50 Hz 200-277/346-480 V 60 Hz	24 V DC
Nominal speed	2700/3200 rpm	2700/3200 rpm	2850/3380 rpm	3200 rpm
Motor rating	0,35/0,42 kW	0,35/0,42 kW	0,37/0,44 kW	0,42 kW
Current consumption	3,9/3,4 A	9,0/8,4 A	2,77/1,60/2,25/1,30 A	30 A
Motor insulation class	F	F	F	F
Protection class	IP54	IP54	IP54	IP55
Thermal protector	yes	yes	no	no
UL recognized motor	no	yes	no	no

General Data				
Ambient temperature	0 to 40 °C	0 to 40 °C	0 to 40 °C	0 to 40 °C
Weight	10,3 kg	10,3 kg	10,1 kg	11,8 kg
Direction of rotation	ccw	ccw	ccw	ccw
Average noise level	60/62 dB (A)	60/62 dB (A)	60/62 dB (A)	67 dB (A)

All listed flow values relate to air at the pump inlet condition (i.e. expanded under vacuum).  
Further information (general usage, installation, servicing etc.) is available in the operating instructions manual.  
Further UL recognized motor on request.

## Flow Curves

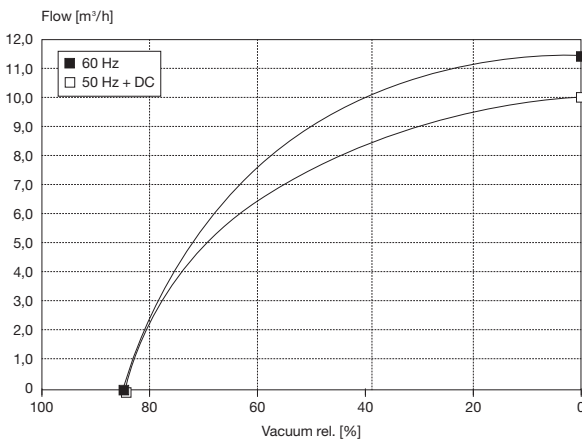

### Supplied as standard:

Tube connector G 3/8  
(Tube I.D. 11 – 13 mm)  
Outlet silencer G 3/8

### Accessories:

Vacuum regulator ZRV 12 G 3/8  
(part number 31490)  
Non-return valve ZRK 12 G 3/8  
(part number 61803)

### Service Parts:

Service kit (part number 27740104)

consists of:

- 4 x Vanes
- 1 x Filter cartridge
- 2 x Filter seal (ring)
- 1 x Filter seal
- 3 x Gasket (copper)
- 1 x O-ring (inside silencer)

The information presented in this material is based on technical data and test results of nominal units. It is believed to be accurate and reliable and is offered as an aid to help in the selection of Thomas products. It is the responsibility of the user to determine the suitability of the product for the intended use and the user assumes all risk and liability whatsoever in connection therewith. Thomas does not warrant, guarantee or assume any obligation or liability in connection with this information.

2774... Stock programme

**THOMAS**  
by Gardner Denver

# Rotary Vane Pump DTE 10



<b>Flow</b>	<b>10/12 m<sup>3</sup>/h</b>
<b>Max. pressure</b>	<b>1,0 bar</b>

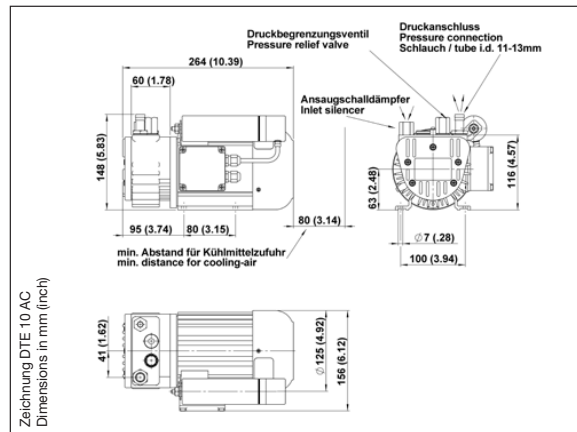

Pneumatic Data				
Description	DTE 10 230/50/60	DTE 10 115/50/60	DTE 10 Three-phase 50/60	DTE 10 24 DC
Part number	27750225	27750226	27750227	27750274
Max. flow	10/12 m <sup>3</sup> /h	10/12 m <sup>3</sup> /h	10/12 m <sup>3</sup> /h	10 m <sup>3</sup> /h
Max. intermittent pressure	0,8 bar	0,8 bar	1,0 bar	1,0 bar
Max. continuous pressure	0,8 bar	0,8 bar	1,0 bar	1,0 bar

Electrical Data				
Motor type	Capacitor	Capacitor	Three-phase	Permanent magnet
Nominal voltage	230 V ±10% 50/60Hz	100 V ±10% 50 Hz 100-115 V ±10% 60 Hz	200-255/346-440 V 50 Hz 200-277/346-480 V 60 Hz	24 V DC
Nominal speed	2700/3200 rpm	2700/3200 rpm	2850/3380 rpm	3200 rpm
Motor rating	0,35/0,42 kW	0,35/0,42 kW	0,37/0,44 kW	0,42 kW
Current consumption	3,9/3,4 A	9,0/8,4 A	2,77/1,60/2,25/1,30 A	30 A
Motor insulation class	F	F	F	F
Protection class	IP54	IP54	IP54	IP55
Thermal protector	yes	yes	no	no
UL recognized motor	no	yes	no	no

General Data				
Ambient temperature	0 to 40 °C	0 to 40 °C	0 to 40 °C	0 to 40 °C
Weight	10,3 kg	10,3 kg	10,1 kg	11,8 kg
Direction of rotation	ccw	ccw	ccw	ccw
Average noise level	63/64 dB (A)	63/64 dB (A)	63/64 dB (A)	68 dB (A)

All listed flow values relate to air at standard atmospheric conditions.  
Further information (general usage, installation, servicing etc.) is available in the operating instructions manual.  
Further UL recognized motor on request.

## Flow Curves

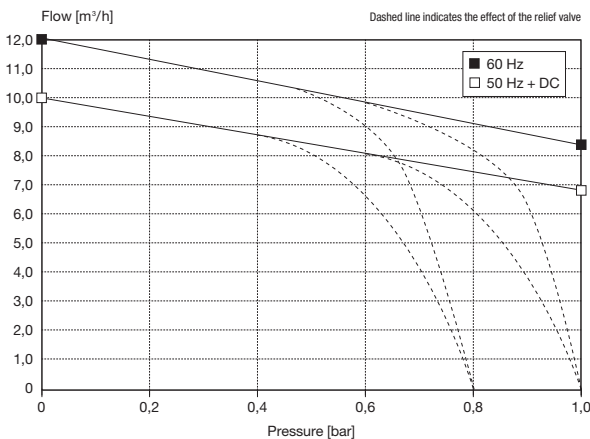

## Supplied as standard:

- Tube connector G 3/8
- (Tube I.D. 11 – 3 mm)
- Outlet silencer G 3/8
- Pressure relief valve (0,8/1,0 bar)
- G 3/8

## Accessories:

- Pressure regulator ZRD 12 G 3/8 (part number 31431)
- Non-return valve ZRK 12 G 3/8 (part number 61803)

2775... Stock programme

## Service Parts:

- Service kit (part number 27740104) consists of:
- 4 x Vanes
- 1 x Filter cartridge
- 2 x Filter seal (ring)
- 1 x Filter seal
- 3 x Gasket (copper)
- 1 x O-ring (only for VTE needed)

The information presented in this material is based on technical data and test results of nominal units. It is believed to be accurate and reliable and is offered as an aid to help in the selection of Thomas products. It is the responsibility of the user to determine the suitability of the product for the intended use and the user assumes all risk and liability whatsoever in connection therewith. Thomas does not warrant, guarantee or assume any obligation or liability in connection with this information.

